

de BETRIEBSANLEITUNG

en OPERATING INSTRUCTION

fr NOTICE D'UTILISATION



**MILCHZENTRIFUGE FJ 350 EAR
CREAM SEPARATOR FJ 350 EAR
CENTRIFUGEUSE À LAIT FJ 350 EAR**

230 V - Type 17582-4
115 V - Type 17582-115-4



JANSCHITZ GmbH | Eisenstraße 81 | A-9330 Althofen
T: +43 4262-2251-0 | F: +43 4262-2251-13
E: office@janschitz-gmbh.at | www.janschitz-gmbh.at

	Seite
General Safety Recommendations _____	15
Technical Specifications _____	16
Unpacking and Set Up _____	16
Accessories _____	16
How to assemble the Cream Separator _____	17
Top Bowl assembling Procedure _____	18
Skimming Procedure _____	19
Skimming Regulation _____	20
Maintenance and Cleaning _____	20
Top Bowl cleaning procedure _____	21
Zeichnung und Teileliste _____	22-23
Spare parts ordering Procedure _____	24
Warranty _____	24

Dear Customer!

We are happy, that you have chosen Milky. We hope, that our device will serve you as a helpful tool for a long time without any problems. We would be happy, if you could recommend us to your friends.

GENERAL SAFETY RECOMMENDATIONS



BEFORE ANY INSTALLATION, READ THIS MANUAL VERY CAREFULLY.



MAKE SURE, THAT YOU HAVE CLOSED TOP BOWL FIXING NUT TIGHTLY.



DISCONNECT DEVICE FROM MAINS BEFORE CLEANING.



DON'T REPAIR THE DEVICE BY YOURSELF, IN CASE OF MALFUNCTION RATHER CALL AUTHORIZED SERVICE PROVIDED BY YOUR DISTRIBUTOR.



PROTECT THE UNIT FOR MOISTURE AND WATER



TAKE CARE THAT WATER OR HUMIDITY WILL NOT COME INTO THE DEVICE, ESPECIALLY BY CLEANING PROCEDURES.



THE MOTOR OF THE SEPARATOR ALWAYS HAS TO BE SWITCHED ON FOR ABOUT 3 MINUTES BEFORE STARTING THE SEPARATION, OTHERWISE THE RESULT IS INCORRECT SEPARATING.



THE SUSPENSION SYSTEM OF THE MOTOR IS THE FLOATING TYPE. THEREFORE, DO NOT BE SURPRISED IF BY TOUCHING THE MOTOR SHAFT CERTAIN MOBILITY IS NOTICED. IT SHOULD NEVER BE RIGID. THE TOP BOWL IS SITUATED RIGHT AT THE CENTER OF THE MACHINE AND AT A GOOD HEIGHT. THE SUSPENSION CAN BE ADJUSTED BUT SHOULD NOT BE MODIFIED UNDER ANY CIRCUMSTANCES.



IN PRACTICE THE ONLY MAINTENANCE OF CREAM SEPARATOR IS CHANGING THE CARBON BRUSHES, WHICH SHOULD BE REPLACED BY AUTHORIZED SERVICE BEFORE THEY ARE COMPLETELY WORN OUT. CHECK THE CARBON BRUSHES WHEN THE MOTOR STARTS RUNNING SLOWER OR IS NOT RUNNING SMOOTHLY OR STOPS.



IN CASE OF SERIOUS MALFUNCTIONS, UNPLUG THE DEVICE FROM MAINS AND CALL AUTHORIZED SERVICE.



IN CASE, THAT THE DEVICE IS NOT FUNCTIONING PROPERLY, EVEN YOU HAVE EXACTLY FOLLOWED INSTRUCTIONS DESCRIBED IN THIS MANUAL, YOU ARE ALLOWED TO USE ONLY THOSE PROCEDURES, WHICH ARE ALLOWED BY THE USER MANUAL. USE OF ANY OTHER PROCEDURES OR ADJUSTMENTS COULD RESULT IN DEVICE DESTRUCTION OR LONGER SERVICE TIME. INJURIES CONNECTED WITH SUCH PROCEDURES CANNOT BE MATTER OF ANY PRODUCT LIABILITY CLAIMS.

We are happy that you have decided to buy our cream separator.

We guarantee, that with the right use and application the cream separator will work properly.

TECHNICAL SPECIFICATION

Item		MZF FJ 350
Operating Voltage (model 230V)	V / Hz	230 / 50
Operating Voltage (model 115V)	V / Hz	115 / 60
Motor Power	W	250
Max. Rotating speed	RPM	7500
Max. Container capacity	l	22
Recommended capacity for skimming	l	250
Net weight	kg	13
Protection type		IP 23
Teller glatt	(Stk.)	14
Nettogewicht	(kg)	13
Schutzklasse	IP	23

Recommended skimming capacity is volume of the milk that can be skimmed within one skimming cycle. It depends how much solid parts are in the milk. If the flow of the skimmed milk is reduced than the discs and the bowl must be cleaned.

UNPACKING AND SET UP

Unpack the device carefully and check, if nothing is left in the cardboard box. Place it on a plain and stable surface in clear, dry and dust-free place.

ACCESSORIES

In each package you will find also following accessories:

- Operating Manual
- Cleaning brush
- Key for bowl nut fixing and cream screw
- Spare rubber washer

Please note!

Be careful and do not use the cream separator with damaged mains cord!

Be careful, that the socket is not damaged!

HOW TO ASSAMBLE THE CREAM SEPARATOR

1. Put the housing on a desk or other plain and stable surface.
2. Put assembled top bowl on the rubber cone fixed on the end of the motor shaft. Knock slightly on top of the bowl so that it sticks securely on the cone.
3. Put milk funnel (conical shape) on the top of the outlet holder and then also cream funnel (concave shape) on the top of previous one.
4. Turn top bowl with hand and check if it is not touching on the funnels and adjust funnels to desired position for skimming.
5. Place the container holder on the top of both funnels. Place floating device in it. Then place container on the container holder. Fix all parts together by fixing part with handle.
6. Place closing cork in the hole situated in the middle of milk container. The horizontal bar of the closing cork handle must be turned away from the cut in the container (see picture). The milk outflow will be closed.

Cut on the container:

1. Open
2. Closed

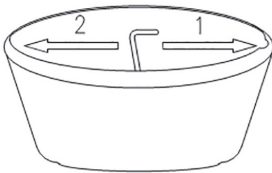

Fixing hooks

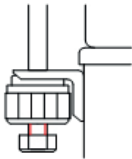

THE CLOSING CORK MUST BE CLOSED WHEN YOU FILL THE CONTAINER WITH MILK. THIS MEANS, THAT THE END OF THE CLOSING CORK HANDLE MUST BE TURNED TO OPPOSITE DIRECTION OF THE CUT IN THE CONTAINER.

TOP BOWL ASSEMBLING PROCEDURES

1. Put the rubber washer into the notch of top bowl bottom part.
2. Place the metal discs in the top bowl. Take care with the placement of the discs - device uses two different types of disks - plain and relief discs. First, insert relief disc, then plain disc and repeat the procedure until all discs are placed. Avoid any use of strength while placing the discs. With gently shaking and turning of the top bowl bottom part all the discs will find their place very easily.
3. Put plastic partition in the top bowl cover part.
4. Place the two parts (top and bottom part) of the top bowl together. Take care that top bowl top part marked with "0" and top bowl bottom part "0" are in the same place and direction.
5. Screw the top bowl fixing nut with hand and fix it strongly with the fixing key. The mark "0" must stay in the same direction. The fixing nut must be strongly fixed, because it is exposed to high forces.

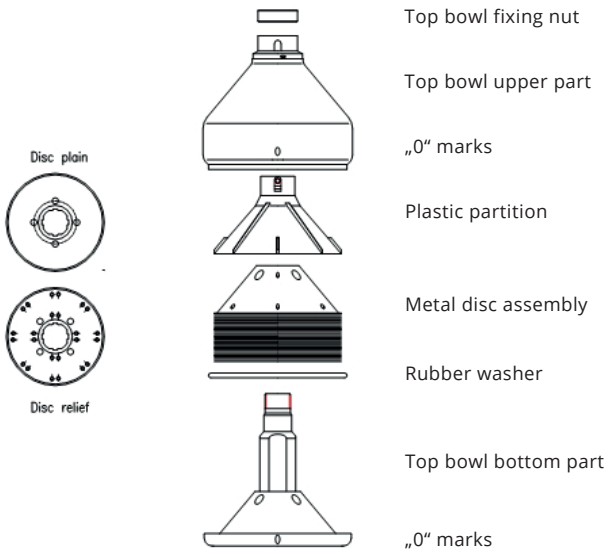

THE TOP BOWL FIXING NUT MUST BE TIGHTENED WELL, BECAUSE IT IS EXPOSED TO CONSIDERABLE FORCES.

SKIMMING PROCEDURE

Best skimming results are achieved, when starting to skim immediately after milking. If milk is cooled, warm it up to a temperature between 30 to 35°C. Milk cannot be skimmed with temperature lower 30°C. When the milk is properly warmed up, pour it in the container.

- Turn on cream separator with I / O switch and wait 120 seconds until top bowl reaches working speed. Cream separator has built in special electronic circuit which provides slow and soft motor start. This prevents sliding of the top bowl on the motor.
- When the motor has reached its working speed turn closing cork to open position. The end of the closing cork is turned to the cut in the container and flow is opened. The skimmed milk must leave the bowl through the four holes in the top bowl and flow out by the lower milk outlet. The cream must leave the bowl through the cream adjusting screw and flow out by the upper cream outlet.

When milk is coming out of the outlets holder holes the closing cork must be closed immediately while the motor is still running. When all the milk has left the bowl the motor must be switched off. Check what is wrong.

- You have opened the closing cork before the motor has reached working speed.
- Top bowl nut was not fixed enough.
- Rubber washer is placed badly, or it is destroyed.

After finishing the process, clean and dry the device carefully!

When the machine starts to work, the top bowl and the discs must always be completely dry.



IF YOU ALREADY FINISHED SKIMMING AND SHUT DOWN THE ENGINE, IT IS PROHIBITED TO START THE ENGINE AGAIN AS LONG AS THE REST MILK HASN'T BEEN COMPLETELY DRAINED AND REMOVED. AFTER YOU HAVE FINISHED SKIMMING, POUR APPROXIMATELY 12 L OF SKIMMED MILK BACK INTO MILK CONTAINER. THIS WILL CLEAN THE REST OF CREAM IN THE TOP BOWL. AFTER ALL PROCEDURES ARE FINISHED, SIMPLY TURN OFF THE DEVICE AND WAIT UNTIL MOTOR STOPS.



ALWAYS CHECK, WHETHER THE RUBBER WASHER IS DAMAGED OR TOO MUCH EXTENDED. IN SUCH CASES PLEASE REPLACE IT WITH A NEW ONE.

SKIMMING REGULATION

The cream separator is factory adjusted with around 10 % of cream from whole milk volume at milk temperature 35°C. It is possible to adjust this percentage due to different conditions like density or volume of cream. Adjust hexagonal adjusting cream screw by turning it (placed in the plastic partition in top bowl upper part).

- For more density cream – less volume, turn it towards right (clockwise)
- For less density cream – higher volume, turn it towards left (counter clockwise). In most cases it is enough to turn the adjusting screw for $\frac{1}{4}$ of the rotation.

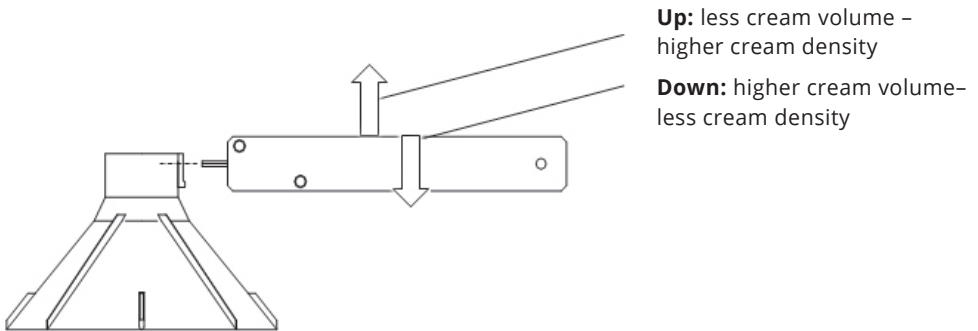

TAKE CARE, NOT TO FIX THE ADJUSTING CREAM SCREW TOO DEEP. THIS CAN CAUSE HARM TO THE SCREW COIL. DON'T UNSCREW THE REGULATION SCREW TOO MUCH. THIS CAN CAUSE PROBLEMS WITH DISASSEMBLING THE PLASTIC PARTITION AND THE TOP BOWL UPPER PART.

MAINTENANCE AND CLEANING

1. After use clean the cream separator parts (except motor part) thoroughly with a neutral detergent that does not affect the aluminum, the rubber washer and other parts of the separator. Do not use an acid or alkaline or other aggressive detergent.
2. Rests of milk, cream or other impairs should be cleaned with soft duster or cleaning brush. Especially take care to clean very precisely all the holes in top bowl upper part, top bowl bottom part and in adjusting screw. For cleaning these parts, a cleaning brush is strongly recommended! Other parts of the separator, which come in touch with milk, should also be cleaned with hot water in which a detergent is added. Then rinse parts in clean water.
3. If milk or cream rests get dry, do not remove them with sharp objects or sharp duster. It can easily happen, that the galvanic protection covers, or plastic parts are damaged.
4. Before cleaning cream separators housing, disconnect device from mains. Clean it first with wet duster and then try it with dry duster. Take care, that water doesn't come into the device.

Ensure, that no water comes in contact with the motor and other electric parts. The device is protected against direct water access, please take care and avoid, that water comes into the device. Before cleaning, always disconnect the Cream Separator from the mains supply.

TOP BOWL CLEANING PROCEDURE

With the key, which is packed with the cream separator, unscrew the top bowl fixing nut as it is shown on the picture below.

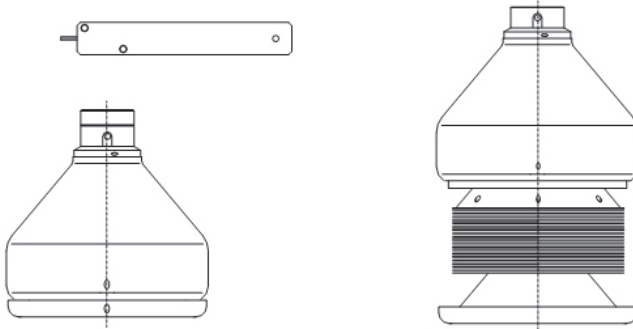

The easiest way to perform this procedure is:

1. Fix key into the holes, which are on the top bowl fixing nut.
2. Press the key down and turn it until the fixing nut is released. It is now possible to unscrew the fixing nut by hand.

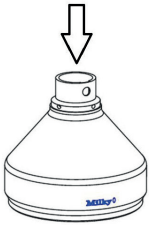

3. Dismount the top bowl cover with the help of the key and separate all different pieces, which are found under the cover - plastic partition, metal discs and rubber washer. Clean them with hot water. To achieve better results, cleaning detergent can be added to the hot water.
4. Wash all the parts with hot water and dry them with dry and soft duster.
5. Never wash the discs in the dishwasher!



IF IT IS NOT POSSIBLE TO MOUNT OFF THE TOP BOWL FROM THE MOTOR AFTER SKIMMING, PLEASE SHAKE IT GENTLY. PLEASE AVOID USING FORCE - IT CAN CAUSE HARM TO THE DEVICE AND MOST OF THE PARTS.

TECHNICAL DRAWING & PART LIST

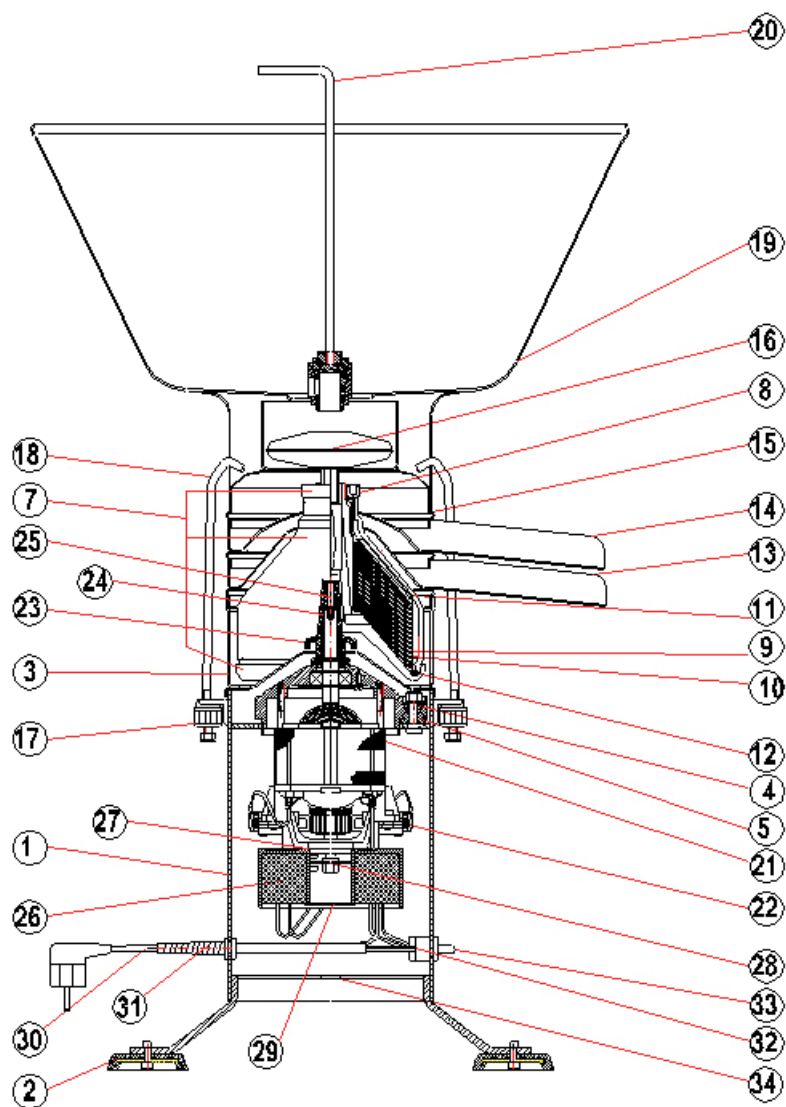

PART LIST

	Name	Part. no. FJ 350 EAR
1	Housing	134945
2	Foot	134609
3	Outlets holder	434589
4	Shock absorber - lower	134577
5	Shock absorber - upper	134578
6	Washer - Inox	105107
7	Top bowl balanced	434577
8	Top bowl fixing nut	434586
9	Metal disk - relief	134665
10	Metal disk - plain	134666
11	Plastic partition	434677
12	Rubber washer	134579
13	Milk funnel	134946
14	Cream funnel	134947
15	Container holder	134948
16	Floating device	104541
17	Mutter for holder	133491
18	Holder	434591
19	Container	134588
20	Closing cork	434591
21	Motor complete 230 V	434897
21	Motor complete 115 V	434934
22	Motor brush	103716
23	Bearing cover	133492
24	Coninical part	434899
25	Screw M4 lest	434680
26	Speed regulation 230 V	201516
26	Speed regulation 115 V	203037
27	Washer for regulation	214626
28	Speed controller	201494
29	Cover of speed controller	201495
30	Mains cord 230 V	400127
31	Mains cord holder	103861
32	Mains switch	103490
33	Cover for mains switch	103491
34	Bottom cover	143953
	Bottom part complete	135106
	Fixing key	434681
	Cleaning brush	102672
	Label Milky	103855

SPARE PARTS ORDERING PROCEDURE

Fast and reliable shipment of spare parts is only possible, if the description is clear enough. At the time of ordering please state clearly:

- Type of cream separator.
- Serial number printed on the label plate at the bottom side of the device.
- Part name and code number of wished spare part.

WARRANTY

In case of troubles consult your distributor or call authorized service.

Equipment is warranted to be free from defects in material and workmanship for a period of 12 months against faulty components and assembly. Our obligation under this warranty is limited to the repair or replacement of the instrument or part thereof, which shall within 12 months after date of shipment prove to be defective after our examination.

Defects or injuries of the device, which are result of improper assembly, use, connect or maintenance are not covered by this warranty.

The warranty also doesn't cover:

- Motor, destroyed by water or milk inflow,
- Brushes
- Mains cord.
- Service through unauthorized people
- Transport cost

Other rights, which are not included in the above mentioned obligations of the producer, like injuries of people, are excluded.

Other rights, that are not mentioned in upper obligations of the manufacturer, especially responsibility for personal injury, are excluded.



Janschitz GmbH

Eisenstrasse 81
9330 Althofen
AUSTRIA

Tel.: +43 4262 2251-0
Fax: +43 4262 2251-13
Email: office@janschitz-gmbh.at
www.janschitz-gmbh.at

